

NOTE: BREAK ALL CORNERS WITH 0.015" (.38 MM) RADIUS UNLESS OTHERWISE NOTED. STANDARD TOLERANCES TO APPLY UNLESS OTHERWISE SPECIFIED.

CUSTOMER PART No.	CUSTOMER <b>CAN ART OPEN</b>	DIE No. <b>ES12233</b>
DESCRIPTION <b>WIRELOCK</b>		PROPOSAL No. <b>S-11913</b>

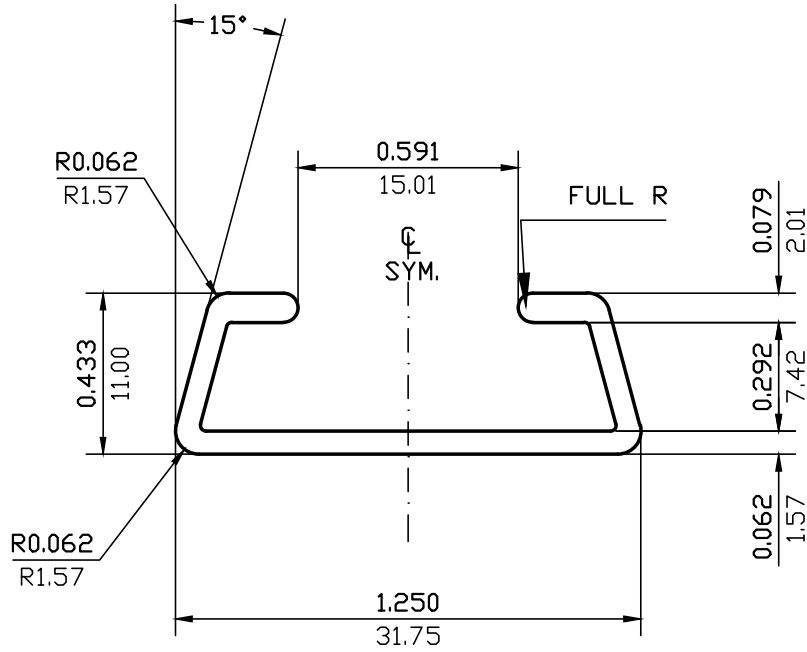

ACTUAL SIZE

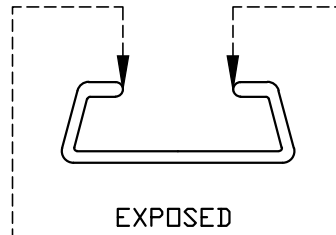

WALL THICKNESS 0.062(1.57) EXCEPT AS SHOWN

DATE	REV	DESCRIPTION	BY
EST.AREA	0.150	IN. <sup>2</sup>	EST.AREA 96.583
EST.WT.	0.177	LBS/FT.	EST.WT. 0.263
EST.PER.	4.694	IN.	EST.PER. 119.230
OUT PER.		IN.	OUT PER.
C.C.D.	1.251	IN.	C.C.D. 31.767
FACTOR	27	FINISH	M/F
		ALLOY & TEMP.	6005A
CKD BY	SCALE 2:1	DWN BY	C.P. DATE 01/28/2002

# CAN ART

ALUMINUM EXTRUSION INC.

85 PARKSHORE DRIVE  
BRAMPTON, ONT L6T 5M1  
TEL. NO. (905) 791-1464  
FAX NO. (905) 791-9151  
E-MAIL: canart@canart.com

THIS DRAWING IS NOT NECESSARILY A COPY OF YOUR ORIGINAL. PLEASE APPROVE DIMENSIONS AND TOLERANCES INDICATED. CAN ART ASSUMES NO RESPONSIBILITY EITHER TECHNICAL OR LEGAL FOR HAVING THIS SHAPE MADE. THE CUSTOMER AGREES TO FULLY PROTECT CAN ART ALUMINUM FROM CLAIMS OF OTHERS RESULTING FROM THIS SHAPE.

SIGNED: \_\_\_\_\_ DATE: \_\_\_\_\_